

# STAR™ Super Seal Key-Lock®

## APPLICATIONS

- Potable Water
- Produced Water
- Waste Water
- Seawater
- Crude Oil & Gas
- Brine
- Drainage Systems
- Sewage
- Brackish Water
- Pipe Rehabilitation
- General Industrial Service

## PRODUCT DESCRIPTION

- **Sizes** - 8 through 40 inches (200-1000 mm)
- **Pressure** - 300 to 3,000 psi (2.1-20.7 MPa)
- **Temperature** - 150°F (65°C) & 200°F (93°C) Standard. 212°F (100°C) designs available.
- **Resin System** - Aromatic Amine Cured Epoxy
- **Reinforcement** - Premium Fiberglass
- **Joining Systems** - Filament wound glass-fiber reinforced epoxy (GRE) with integral Key-Lock (KL) male and female mechanical joining system.
- **Joint Length** - 39 feet (11.9 mts) nominal
- **Fittings** - Filament wound glass-fiber reinforced fittings with integral KL female bells. A wide range of fittings are available.

## HIGH PRESSURE DESIGN

Laminate designed using API 15HR and ISO 14692 procedures

- **Design Life** - 20 years at full rating
- **Reinforced Wall Thickness** - Minimum
- **Hoop Stress** - 95% Lower Confidence Limit (LCL) of Long-Term Hydrostatic Strength (LTHS), ASTM D2992-B
- **Factory Hydro Test** - All sizes 1.5 times the series pressure rating

## JOINING SYSTEM

- **Key-Lock** - A self-restrained joint offering a quick assembly by utilizing ductile locking keys for mechanical restraint. Joint is directly inserted with no rotation. Available with 1 or more locking keys depending on pressure requirements. Hydrostatic seal is made by means of an elastomeric O-ring.
- **Flanges** - Filament wound GRE stub flanges with integral KL male spigot ends are available. Flange hole patterns per ASME B16.5 and ASME B16.47 with either Class 300, 600, 900 or 1500 standard.

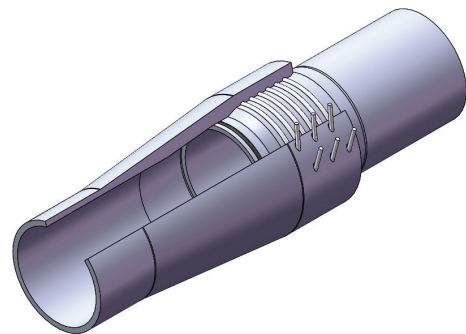

Super Seal Key-Lock

## BENEFITS

- Corrosion Control
- Reduced Installation Costs
- Improved Flow Efficiency
- Reduced Paraffin & Scale Build-Up
- Reduced Maintenance Cost

# STAR Super Seal Key-Lock - Specification Guide

## 150°F (65°C) Series

### Series 300 @ 150°F (65°C) 300 psi (2.1 MPa)

Pipe Dimensions														
Pipe Size		Inside Diameter		Minimum Wall Thickness		Pipe Weight		Nominal Connection Diameter		Minimum Bending Radius		Short-Term Tensile Rating		# of Keys
in	mm	in	mm	in	mm	lbs/ft	kg/m	in	mm	ft	m	lbs	kN	
8	200	8.22	209	0.09	2.3	2.7	4.0	10.1	257	420	128	6700	30	1
10	250	10.35	263	0.11	2.8	4.3	6.4	12.4	315	530	162	10600	47	2
12	300	12.35	314	0.13	3.4	6.1	9.1	14.8	375	630	192	15200	68	2
14	350	13.56	344	0.15	3.7	7.4	11.0	16.1	408	695	212	18300	81	2
16	400	15.50	394	0.17	4.3	9.6	14.3	18.1	461	795	242	23900	106	2
18	450	17.08	434	0.19	4.7	11.7	17.4	20.1	510	875	267	29000	129	2
20	500	18.98	482	0.21	5.2	14.5	21.5	22.1	562	970	296	36000	160	2
24	600	22.78	579	0.25	6.3	20.8	31.0	26.2	666	1165	355	51800	230	2
30	750	29.53	750	0.32	8.2	35.1	52.2	33.6	853	1510	460	87200	388	2
36	900	35.43	900	0.39	9.8	50.5	75.2	40.3	1024	1810	552	125000	556	2
40	1000	39.37	1000	0.43	10.8	62.2	92.6	44.6	1132	2010	613	154000	685	2

### Series 500 @ 150°F (65°C) 500 psi (3.4 MPa)

Pipe Dimensions														
Pipe Size		Inside Diameter		Minimum Wall Thickness		Pipe Weight		Nominal Connection Diameter		Minimum Bending Radius		Short-Term Tensile Rating		# of Keys
in	mm	in	mm	in	mm	lbs/ft	kg/m	in	mm	ft	m	lbs	kN	
8	200	8.22	209	0.15	3.8	4.6	6.8	10.5	267	430	131	11400	51	2
10	250	10.35	263	0.19	4.8	7.3	10.9	12.9	327	540	165	18100	81	2
12	300	12.35	314	0.23	5.7	10.4	15.4	15.4	390	640	195	25700	114	2
14	350	13.56	344	0.25	6.3	12.5	18.6	16.7	425	705	215	31000	138	2
16	400	15.50	394	0.28	7.2	16.4	24.3	18.9	480	805	245	40600	181	2
18	450	17.08	434	0.31	7.9	19.8	29.5	20.9	531	885	270	49200	219	2
20	500	18.98	482	0.35	8.8	24.5	36.4	23.0	585	985	300	60900	271	3
24	600	22.78	579	0.42	10.5	35.3	52.5	27.3	693	1180	360	87600	390	3
30	750	29.53	750	0.54	13.7	59.2	88.2	35.4	898	1530	466	147000	654	3
36	900	35.43	900	0.65	16.4	85.4	127.0	42.0	1066	1835	559	212000	943	3
40	1000	39.37	1000	0.72	18.2	105.4	156.9	46.6	1184	2040	622	262000	1165	3

### Series 750 @ 150°F (65°C) 750 psi (5.2 MPa)

Pipe Dimensions														
Pipe Size		Inside Diameter		Minimum Wall Thickness		Pipe Weight		Nominal Connection Diameter		Minimum Bending Radius		Short-Term Tensile Rating		# of Keys
in	mm	in	mm	in	mm	lbs/ft	kg/m	in	mm	ft	m	lbs	kN	
8	200	8.22	209	0.23	5.8	7.0	10.5	11.0	280	435	133	17400	77	3
10	250	10.35	263	0.29	7.3	11.1	16.6	13.5	343	550	168	27700	123	3
12	300	12.35	314	0.34	8.7	15.8	23.6	16.1	409	655	200	39400	175	3
14	350	13.56	344	0.37	9.5	19.1	28.4	17.5	445	715	218	47400	211	3
16	400	15.50	394	0.43	10.9	25.0	37.2	19.8	502	820	250	62100	276	3
18	450	17.08	434	0.47	12.0	30.3	45.1	22.1	561	900	274	75300	335	3
20	500	18.98	482	0.52	13.3	37.4	55.7	24.2	614	1000	305	93100	414	4
24	600	22.78	579	0.63	16.0	53.9	80.3	28.7	728	1205	367	134000	596	4
30	750	29.53	750	0.82	20.7	90.6	134.8	37.0	939	1560	475	225000	1001	4
36	900	35.43	900	0.98	24.8	130.4	194.1	44.2	1122	1870	570	324000	1441	4
40	1000	39.37	1000	1.09	27.6	160.9	239.5	48.9	1241	2075	632	400000	1779	5

# STAR Super Seal Key-Lock - Specification Guide

## 150°F (65°C) Series

### Series 1000 @ 150°F (65°C) 1000 psi (6.9 MPa)

Pipe Dimensions														
Pipe Size		Inside Diameter		Minimum Wall Thickness		Pipe Weight		Nominal Connection Diameter		Minimum Bending Radius		Short-Term Tensile Rating		# of Keys
in	mm	in	mm	in	mm	lbs/ft	kg/m	in	mm	ft	m	lbs	kN	
8	200	8.22	209	0.31	7.7	9.5	14.2	11.5	292	445	136	23600	105	3
10	250	10.35	263	0.38	9.8	15.1	22.5	14.4	366	560	171	37500	167	4
12	300	12.35	314	0.46	11.7	21.5	32.0	16.9	430	665	203	53500	238	4
14	350	13.56	344	0.50	12.8	25.9	38.6	18.4	466	730	223	64400	286	4
16	400	15.50	394	0.58	14.6	33.9	50.5	20.8	527	835	255	84300	375	4
18	450	17.08	434	0.63	16.1	41.1	61.2	23.0	583	920	280	102000	454	4
20	500	18.98	482	0.71	17.9	50.8	75.6	25.3	643	1020	311	126000	560	5
24	600	22.78	579	0.85	21.5	73.2	108.9	30.0	763	1225	373	182000	810	5
30	750	29.53	750	1.10	27.8	122.9	182.9	38.8	986	1585	483	305000	1357	5
36	900	35.43	900	1.32	33.4	177.0	263.4	46.4	1178	1905	581	440000	1957	5

### Series 1250 @ 150°F (65°C) 1250 psi (8.6 MPa)

Pipe Dimensions														
Pipe Size		Inside Diameter		Minimum Wall Thickness		Pipe Weight		Nominal Connection Diameter		Minimum Bending Radius		Short-Term Tensile Rating		# of Keys
in	mm	in	mm	in	mm	lbs/ft	kg/m	in	mm	ft	m	lbs	kN	
8	200	8.22	209	0.39	9.8	12.1	18.1	12.3	313	450	137	30100	134	4
10	250	10.35	263	0.49	12.3	19.2	28.6	14.8	376	570	174	47800	213	5
12	300	12.35	314	0.58	14.7	27.4	40.8	17.6	448	675	206	68200	303	5
14	350	13.56	344	0.64	16.1	33.0	49.1	19.2	488	745	227	82100	365	5
16	400	15.50	394	0.73	18.4	43.1	64.2	21.7	552	850	259	107000	476	5
18	450	17.08	434	0.80	20.3	52.4	78.0	24.0	610	935	285	130000	578	5
20	500	18.98	482	0.89	22.6	64.7	96.3	26.5	673	1040	317	160000	712	5
24	600	22.78	579	1.07	27.1	93.2	138.7	31.5	800	1245	379	231000	1028	6
30	750	29.53	750	1.38	35.1	156.6	233.0	40.7	1033	1615	492	389000	1730	6

### Series 1500 @ 150°F (65°C) 1500 psi (10.3 MPa)

Pipe Dimensions														
Pipe Size		Inside Diameter		Minimum Wall Thickness		Pipe Weight		Nominal Connection Diameter		Minimum Bending Radius		Short-Term Tensile Rating		# of Keys
in	mm	in	mm	in	mm	lbs/ft	kg/m	in	mm	ft	m	lbs	kN	
8	200	8.22	209	0.47	11.8	14.8	22.1	12.6	319	460	140	36800	164	5
10	250	10.35	263	0.59	14.9	23.5	35.0	15.5	393	580	177	58400	260	6
12	300	12.35	314	0.70	17.8	33.5	49.9	18.4	468	690	210	83300	371	5
14	350	13.56	344	0.77	19.5	40.4	60.1	20.1	510	755	230	100000	445	6
16	400	15.50	394	0.88	22.4	52.8	78.6	22.7	577	865	264	131000	583	6
18	450	17.08	434	0.97	24.6	64.1	95.3	25.1	638	950	290	159000	707	6
20	500	18.98	482	1.08	27.4	79.1	117.7	27.7	704	1060	323	196000	872	6
24	600	22.78	579	1.29	32.8	114.0	169.6	33.0	838	1270	387	283000	1259	7

# STAR Super Seal Key-Lock - Specification Guide

## 150°F (65°C) Series

### Series 1750 @ 150°F (65°C) 1750 psi (12.1 MPa)

Pipe Dimensions														
Pipe Size		Inside Diameter		Minimum Wall Thickness		Pipe Weight		Nominal Connection Diameter		Minimum Bending Radius		Short-Term Tensile Rating		# of Keys
in	mm	in	mm	in	mm	lbs/ft	kg/m	in	mm	ft	m	lbs	kN	
8	200	8.22	209	0.55	13.9	17.6	26.2	13.1	332	470	143	43800	195	5
10	250	10.35	263	0.69	17.6	28.0	41.6	16.1	410	590	180	69600	310	6
12	300	12.35	314	0.83	21.0	39.8	59.2	19.2	488	700	213	99000	440	6
14	350	13.56	344	0.91	23.0	48.0	71.4	21.0	532	770	235	119000	529	6
16	400	15.50	394	1.04	26.3	62.7	93.4	23.7	603	880	268	156000	694	7
18	450	17.08	434	1.14	29.0	76.2	113.4	26.2	666	970	296	189000	841	7
20	500	18.98	482	1.27	32.2	94.1	140.1	29.0	735	1075	328	234000	1041	7

### Series 2000 @ 150°F (65°C) 2000 psi (13.8 MPa)

Pipe Dimensions														
Pipe Size		Inside Diameter		Minimum Wall Thickness		Pipe Weight		Nominal Connection Diameter		Minimum Bending Radius		Short-Term Tensile Rating		# of Keys
in	mm	in	mm	in	mm	lbs/ft	kg/m	in	mm	ft	m	lbs	kN	
8	200	8.22	209	0.63	16.1	20.6	30.6	13.6	346	475	145	51100	227	6
10	250	10.35	263	0.80	20.3	32.6	48.5	16.8	427	600	183	81000	360	7
12	300	12.35	314	0.95	24.2	46.4	69.0	20.0	509	715	218	115000	512	7
14	350	13.56	344	1.05	26.6	56.0	83.3	21.9	555	785	239	139000	618	7
16	400	15.50	394	1.20	30.4	73.1	108.7	24.8	629	895	273	181000	805	8
18	450	17.08	434	1.32	33.5	88.7	132.1	27.4	695	985	300	220000	979	7
20	500	18.98	482	1.46	37.2	109.6	163.1	30.3	770	1095	334	272000	1210	8

### Series 2250 @ 150°F (65°C) 2250 psi (15.5 MPa)

Pipe Dimensions														
Pipe Size		Inside Diameter		Minimum Wall Thickness		Pipe Weight		Nominal Connection Diameter		Minimum Bending Radius		Short-Term Tensile Rating		# of Keys
in	mm	in	mm	in	mm	lbs/ft	kg/m	in	mm	ft	m	lbs	kN	
8	200	8.22	209	0.72	18.3	23.6	35.1	12.3	313	485	148	58600	261	6
10	250	10.35	263	0.91	23.0	37.4	55.6	14.8	376	610	186	93000	414	8
12	300	12.35	314	1.08	27.5	53.2	79.2	17.6	448	725	221	132000	587	7
14	350	13.56	344	1.19	30.2	64.2	95.5	19.2	488	800	244	159000	707	8
16	400	15.50	394	1.36	34.5	83.8	124.8	21.7	552	910	277	208000	925	9
18	450	17.08	434	1.50	38.0	101.8	151.5	24.0	610	1005	306	253000	1125	8

### Series 2500 @ 150°F (65°C) 2500 psi (17.2 MPa)

Pipe Dimensions														
Pipe Size		Inside Diameter		Minimum Wall Thickness		Pipe Weight		Nominal Connection Diameter		Minimum Bending Radius		Short-Term Tensile Rating		# of Keys
in	mm	in	mm	in	mm	lbs/ft	kg/m	in	mm	ft	m	lbs	kN	
8	200	8.22	209	0.81	20.5	26.7	39.8	14.8	375	495	151	66400	295	7
10	250	10.35	263	1.02	25.8	42.3	63.0	18.2	463	620	189	105000	467	8
12	300	12.35	314	1.21	30.8	60.3	89.7	21.7	552	740	226	150000	667	8
14	350	13.56	344	1.33	33.9	72.7	108.2	23.7	602	815	248	180000	801	8
16	400	15.50	394	1.52	38.7	95.0	141.4	26.9	683	930	283	236000	1050	9

# STAR Super Seal Key-Lock - Specification Guide

## 150°F (65°C) Series

### Series 2750 @ 150°F (65°C) 2750 psi (19.0 MPa)

Pipe Dimensions														
Pipe Size		Inside Diameter		Minimum Wall Thickness		Pipe Weight		Nominal Connection Diameter		Minimum Bending Radius		Short-Term Tensile Rating		# of Keys
in	mm	in	mm	in	mm	lbs/ft	kg/m	in	mm	ft	m	lbs	kN	
8	200	8.22	209	0.90	22.8	30.0	44.6	15.3	390	505	154	74500	331	7
10	250	10.35	263	1.13	28.7	47.5	70.7	19.0	482	630	192	118000	525	9
12	300	12.35	314	1.35	34.3	67.7	100.7	22.6	574	755	230	168000	747	8
14	350	13.56	344	1.48	37.6	81.6	121.4	24.7	626	825	251	202000	899	9

### Series 3000 @ 150°F (65°C) 3000 psi (20.7 MPa)

Pipe Dimensions														
Pipe Size		Inside Diameter		Minimum Wall Thickness		Pipe Weight		Nominal Connection Diameter		Minimum Bending Radius		Short-Term Tensile Rating		# of Keys
in	mm	in	mm	in	mm	lbs/ft	kg/m	in	mm	ft	m	lbs	kN	
8	200	8.22	209	0.99	25.1	33.4	49.6	15.9	405	510	155	82900	369	8
10	250	10.35	263	1.25	31.6	52.9	78.7	19.7	501	645	197	131000	583	9
12	300	12.35	314	1.49	37.7	75.3	112.1	23.5	597	765	233	187000	832	9

# STAR Super Seal Key-Lock - Specification Guide

## 200°F (93°C) Series

### Series 300 @ 200°F (93°C) 300 psi (2.1 MPa)

Pipe Dimensions														
Pipe Size		Inside Diameter		Minimum Wall Thickness		Pipe Weight		Nominal Connection Diameter		Minimum Bending Radius		Short-Term Tensile Rating		# of Keys
in	mm	in	mm	in	mm	lbs/ft	kg/m	in	mm	ft	m	lbs	kN	
8	200	8.22	209	0.12	3.0	3.6	5.4	10.3	261	425	130	8900	40	1
10	250	10.35	263	0.15	3.8	5.7	8.5	12.6	320	535	163	14200	63	2
12	300	12.35	314	0.18	4.5	8.2	12.2	15.0	382	635	194	20300	90	2
14	350	13.56	344	0.20	5.0	9.8	14.6	16.3	415	700	213	24400	109	2
16	400	15.50	394	0.22	5.7	12.8	19.1	18.5	469	800	244	31900	142	2
18	450	17.08	434	0.25	6.2	15.6	23.2	20.4	519	880	268	38800	173	2
20	500	18.98	482	0.27	7.0	19.3	28.8	22.5	572	975	297	48000	214	2
24	600	22.78	579	0.33	8.3	27.8	41.3	26.6	677	1175	358	69000	307	2
30	750	29.53	750	0.43	10.8	46.7	69.6	34.2	868	1520	463	116000	516	2
36	900	35.43	900	0.51	13.0	67.3	100.1	41.0	1042	1820	555	167000	743	2
40	1000	39.37	1000	0.57	14.4	82.9	123.4	45.3	1152	2025	617	206000	916	2

### Series 500 @ 200°F (93°C) 500 psi (3.4 MPa)

Pipe Dimensions														
Pipe Size		Inside Diameter		Minimum Wall Thickness		Pipe Weight		Nominal Connection Diameter		Minimum Bending Radius		Short-Term Tensile Rating		# of Keys
in	mm	in	mm	in	mm	lbs/ft	kg/m	in	mm	ft	m	lbs	kN	
8	200	8.22	209	0.20	5.1	6.1	9.1	10.8	274	435	133	15200	68	2
10	250	10.35	263	0.25	6.4	9.7	14.5	13.2	336	545	166	24200	108	2
12	300	12.35	314	0.30	7.6	13.9	20.7	15.8	401	650	198	34500	153	2
14	350	13.56	344	0.33	8.4	16.7	24.9	17.2	436	710	216	41600	185	2
16	400	15.50	394	0.38	9.6	21.9	32.5	19.4	493	815	248	54300	242	2
18	450	17.08	434	0.41	10.5	26.5	39.5	21.5	545	895	273	65900	293	2
20	500	18.98	482	0.46	11.7	32.8	48.7	23.7	601	995	303	81400	362	3
24	600	22.78	579	0.55	14.0	47.2	70.2	28.0	712	1195	364	117000	520	3
30	750	29.53	750	0.72	18.2	79.3	118.0	36.0	914	1550	472	197000	876	3
36	900	35.43	900	0.86	21.8	114.2	169.9	43.2	1097	1855	565	283000	1259	3
40	1000	39.37	1000	0.96	24.3	141.0	209.9	47.7	1213	2065	629	350000	1557	3

### Series 750 @ 200°F (93°C) 750 psi (5.2 MPa)

Pipe Dimensions														
Pipe Size		Inside Diameter		Minimum Wall Thickness		Pipe Weight		Nominal Connection Diameter		Minimum Bending Radius		Short-Term Tensile Rating		# of Keys
in	mm	in	mm	in	mm	lbs/ft	kg/m	in	mm	ft	m	lbs	kN	
8	200	8.22	209	0.30	7.7	9.5	14.1	11.0	280	445	136	23500	105	3
10	250	10.35	263	0.38	9.7	15.0	22.3	13.5	343	555	169	37200	165	3
12	300	12.35	314	0.46	11.6	21.3	31.8	16.1	409	665	203	53000	236	3
14	350	13.56	344	0.50	12.7	25.7	38.2	17.5	445	730	223	63900	284	3
16	400	15.50	394	0.57	14.5	33.6	50.0	21.1	536	835	255	83600	372	3
18	450	17.08	434	0.63	16.0	40.8	60.7	22.8	579	920	280	101000	449	3
20	500	18.98	482	0.70	17.8	50.4	75.0	25.1	639	1020	311	125000	556	4
24	600	22.78	579	0.84	21.3	72.6	108.0	29.8	757	1225	373	180000	801	4
30	750	29.53	750	1.09	27.6	121.9	181.4	38.5	978	1585	483	303000	1348	4
36	900	35.43	900	1.31	33.1	175.6	261.3	46.0	1169	1900	579	436000	1939	4
40	1000	39.37	1000	1.45	36.8	216.8	322.6	50.9	1293	2115	645	539000	2398	5

# STAR Super Seal Key-Lock - Specification Guide

## 200°F (93°C) Series

### Series 1000 @ 200°F (93°C) 1000 psi (6.9 MPa)

Pipe Dimensions														
Pipe Size		Inside Diameter		Minimum Wall Thickness		Pipe Weight		Nominal Connection Diameter		Minimum Bending Radius		Short-Term Tensile Rating		# of Keys
in	mm	in	mm	in	mm	lbs/ft	kg/m	in	mm	ft	m	lbs	kN	
8	200	8.22	209	0.41	10.4	12.9	19.2	12.1	307	455	139	32100	143	3
10	250	10.35	263	0.52	13.1	20.5	30.5	14.9	378	570	174	50900	226	4
12	300	12.35	314	0.61	15.6	29.2	43.4	17.7	450	680	207	72500	322	4
14	350	13.56	344	0.67	17.1	35.1	52.3	19.3	491	745	227	87400	389	4
16	400	15.50	394	0.77	19.6	45.9	68.4	21.9	555	855	261	114200	508	4
18	450	17.08	434	0.85	21.6	55.7	83.0	24.2	614	940	287	138600	617	4
20	500	18.98	482	0.94	24.0	68.9	102.5	26.7	677	1045	319	171300	762	5
24	600	22.78	579	1.13	28.8	99.1	147.5	31.6	804	1255	383	246600	1097	5
30	750	29.53	750	1.47	37.3	166.7	248.0	40.9	1039	1625	495	414500	1844	5
36	900	35.43	900	1.76	44.7	239.9	357.0	48.9	1242	1945	593	596600	2654	5

### Series 1250 @ 200°F (93°C) 1250 psi (8.6 MPa)

Pipe Dimensions														
Pipe Size		Inside Diameter		Minimum Wall Thickness		Pipe Weight		Nominal Connection Diameter		Minimum Bending Radius		Short-Term Tensile Rating		# of Keys
in	mm	in	mm	in	mm	lbs/ft	kg/m	in	mm	ft	m	lbs	kN	
8	200	8.22	209	0.52	13.1	16.5	24.6	12.8	324	465	142	41100	183	4
10	250	10.35	263	0.65	16.5	26.2	39.0	15.7	400	585	178	65200	290	5
12	300	12.35	314	0.78	19.7	37.4	55.6	18.8	476	695	212	92900	413	5
14	350	13.56	344	0.85	21.7	45.0	67.0	20.4	519	765	233	112000	498	5
16	400	15.50	394	0.98	24.8	58.8	87.5	23.1	588	875	267	146300	651	5
18	450	17.08	434	1.08	27.3	71.5	106.4	25.6	650	965	294	177800	791	5
20	500	18.98	482	1.19	30.3	88.2	131.3	28.2	717	1070	326	219400	976	5
24	600	22.78	579	1.43	36.4	127.1	189.1	33.6	853	1285	392	316100	1406	6
30	750	29.53	750	1.86	47.2	213.6	317.9	43.4	1101	1660	506	531300	2363	6

### Series 1500 @ 200°F (93°C) 1500 psi (10.3 MPa)

Pipe Dimensions														
Pipe Size		Inside Diameter		Minimum Wall Thickness		Pipe Weight		Nominal Connection Diameter		Minimum Bending Radius		Short-Term Tensile Rating		# of Keys
in	mm	in	mm	in	mm	lbs/ft	kg/m	in	mm	ft	m	lbs	kN	
8	200	8.22	209	0.63	16.0	20.4	30.3	13.5	342	475	145	50700	226	5
10	250	10.35	263	0.79	20.1	32.3	48.0	16.6	422	600	183	80200	357	6
12	300	12.35	314	0.94	24.0	46.0	68.4	19.8	503	715	218	114300	508	5
14	350	13.56	344	1.04	26.3	55.4	82.5	21.6	548	785	239	137900	613	6
16	400	15.50	394	1.19	30.1	72.4	107.8	24.4	621	895	273	180100	801	6
18	450	17.08	434	1.31	33.2	87.9	130.9	27.0	686	985	300	218700	973	6
20	500	18.98	482	1.45	36.9	108.6	161.6	29.8	757	1095	334	270000	1201	6
24	600	22.78	579	1.74	44.2	156.5	232.8	35.5	902	1315	401	389100	1731	7

# STAR Super Seal Key-Lock - Specification Guide

## 200°F (93°C) Series

### Series 1750 @ 200°F (93°C) 1750 psi (12.1 MPa)

Pipe Dimensions														
Pipe Size		Inside Diameter		Minimum Wall Thickness		Pipe Weight		Nominal Connection Diameter		Minimum Bending Radius		Short-Term Tensile Rating		# of Keys
in	mm	in	mm	in	mm	lbs/ft	kg/m	in	mm	ft	m	lbs	kN	
8	200	8.22	209	0.74	18.9	24.4	36.3	14.2	360	485	148	60600	270	5
10	250	10.35	263	0.94	23.7	38.6	57.5	17.5	444	615	187	96100	427	6
12	300	12.35	314	1.12	28.3	55.0	81.9	20.9	530	730	223	136000	605	6
14	350	13.56	344	1.23	31.1	66.3	98.7	22.7	578	800	244	165000	734	6
16	400	15.50	394	1.40	35.6	86.7	129.1	25.8	655	915	279	215000	956	7
18	450	17.08	434	1.54	39.2	105.2	156.6	28.5	724	1010	308	261000	1161	7
20	500	18.98	482	1.72	43.6	130.0	193.4	31.5	799	1120	341	323000	1437	7

### Series 2000 @ 200°F (93°C) 2000 psi (13.8 MPa)

Pipe Dimensions														
Pipe Size		Inside Diameter		Minimum Wall Thickness		Pipe Weight		Nominal Connection Diameter		Minimum Bending Radius		Short-Term Tensile Rating		# of Keys
in	mm	in	mm	in	mm	lbs/ft	kg/m	in	mm	ft	m	lbs	kN	
8	200	8.22	209	0.86	21.8	28.6	42.6	14.9	379	500	152	71100	316	6
10	250	10.35	263	1.08	27.5	45.3	67.5	18.4	468	625	191	112000	498	7
12	300	12.35	314	1.29	32.8	64.6	96.1	22.0	558	750	229	160000	712	7
14	350	13.56	344	1.42	36.0	77.8	115.8	23.9	608	820	250	193000	859	7
16	400	15.50	394	1.62	41.2	101.7	151.4	27.1	690	940	287	253000	1125	8
18	450	17.08	434	1.79	45.4	123.5	183.8	30.0	762	1035	315	307000	1366	7
20	500	18.98	482	1.99	50.4	152.5	226.9	33.3	845	1150	351	379000	1686	8

### Series 2250 @ 200°F (93°C) 2250 psi (15.5 MPa)

Pipe Dimensions														
Pipe Size		Inside Diameter		Minimum Wall Thickness		Pipe Weight		Nominal Connection Diameter		Minimum Bending Radius		Short-Term Tensile Rating		# of Keys
in	mm	in	mm	in	mm	lbs/ft	kg/m	in	mm	ft	m	lbs	kN	
8	200	8.22	209	0.98	24.9	33.0	49.1	12.8	324	510	155	82100	365	6
10	250	10.35	263	1.23	31.3	52.4	77.9	15.7	400	640	195	130000	578	8
12	300	12.35	314	1.47	37.4	74.6	111.0	18.8	476	765	233	185000	823	7
14	350	13.56	344	1.62	41.1	89.9	133.8	20.4	519	840	256	223000	992	8
16	400	15.50	394	1.85	47.0	117.5	174.8	23.1	588	960	293	292000	1299	9
18	450	17.08	434	2.04	51.7	142.6	212.2	25.6	650	1060	323	354000	1575	8

### Series 2500 @ 200°F (93°C) 2500 psi (17.2 MPa)

Pipe Dimensions														
Pipe Size		Inside Diameter		Minimum Wall Thickness		Pipe Weight		Nominal Connection Diameter		Minimum Bending Radius		Short-Term Tensile Rating		# of Keys
in	mm	in	mm	in	mm	lbs/ft	kg/m	in	mm	ft	m	lbs	kN	
8	200	8.22	209	1.10	28.0	37.7	56.1	16.4	417	525	160	93700	417	7
10	250	10.35	263	1.39	35.3	59.8	88.9	20.3	516	660	201	148000	658	8
12	300	12.35	314	1.66	42.1	85.1	126.7	24.2	615	785	239	211000	939	8
14	350	13.56	344	1.82	46.3	102.6	152.7	26.5	672	860	262	255000	1134	8
16	400	15.50	394	2.08	52.9	134.1	199.5	30.0	762	985	300	333000	1481	9



# STAR Super Seal Key-Lock - Specification Guide

## 200°F (93°C) Series

### Series 2750 @ 200°F (93°C) 2750 psi (19.0 MPa)

Pipe Dimensions														
Pipe Size		Inside Diameter		Minimum Wall Thickness		Pipe Weight		Nominal Connection Diameter		Minimum Bending Radius		Short-Term Tensile Rating		# of Keys
in	mm	in	mm	in	mm	lbs/ft	kg/m	in	mm	ft	m	lbs	kN	
8	200	8.22	209	1.23	31.3	42.6	63.4	17.2	437	535	163	105000	467	7
10	250	10.35	263	1.55	39.4	67.6	100.5	21.3	542	675	206	168000	747	9
12	300	12.35	314	1.85	47.0	96.2	143.1	25.4	646	805	245	239000	1063	8
14	350	13.56	344	2.03	51.6	115.9	172.5	27.8	705	880	268	288000	1281	9

### Series 3000 @ 200°F (93°C) 3000 psi (20.7 MPa)

Pipe Dimensions														
Pipe Size		Inside Diameter		Minimum Wall Thickness		Pipe Weight		Nominal Connection Diameter		Minimum Bending Radius		Short-Term Tensile Rating		# of Keys
in	mm	in	mm	in	mm	lbs/ft	kg/m	in	mm	ft	m	lbs	kN	
8	200	8.22	209	1.36	34.6	47.8	71.1	18.0	458	550	168	118000	525	8
10	250	10.35	263	1.71	43.5	75.7	112.7	22.3	568	690	210	188000	836	9
12	300	12.35	314	2.05	51.9	107.8	160.4	26.6	677	825	251	268000	1192	9

# STAR Super Seal Key-Lock - Specification Guide

## Typical Mechanical Properties

Pipe Property		70°F	21°C	150°F	65°C	200°F	93°C	Method
		psi	MPa	psi	MPa	psi	MPa	
Hydrostatic Design Basis	(LTHS)	23,400 <sup>(1)</sup>	161 <sup>(1)</sup>	23,400	161	17,500	121	ASTM D2992, Proc. B (20 yrs)
	(LCL)	20,900 <sup>(1)</sup>	144 <sup>(1)</sup>	20,900	144	15,800	109	
Ultimate Hoop Stress at Weeping		36,000	248	45,400	313	48,400	334	ASTM D1599

### Circumferential

Hoop Tensile Modulus		3.84 x 10 <sup>6</sup>	26,500	2.86 x 10 <sup>6</sup>	19,700	2.25 x 10 <sup>6</sup>	15,500	NOV FGS
Poisson's Ratio $v_{ha}$		0.61		0.73		0.80		NOV FGS

### Longitudinal

Axial tensile strength		11,600	80	10,100	70	9,200	63.4	ASTM D2105
Axial Modulus		2.24 x 10 <sup>6</sup>	15,500	1.53 x 10 <sup>6</sup>	11,200	1.24 x 10 <sup>6</sup>	8,550	ASTM D2105
Poisson's Ratio $v_{ah}$		0.35		0.39		0.42		ASTM D2105
Axial Bending Strength		12,300	85	-	-	-	-	NOV FGS
Axial Bending Modulus		2.25 x 10 <sup>6</sup>	15,500	1.75 x 10 <sup>6</sup>	12,100	1.43 x 10 <sup>6</sup>	9,900	ASTM D2925
Shear Modulus		1.76 x 10 <sup>6</sup>	12,100	1.65 x 10 <sup>6</sup>	11,400	1.58 x 10 <sup>6</sup>	10,900	NOV FGS

<sup>(1)</sup> Value obtained at 150°F

<sup>(2)</sup>  $v_{ha}$  = The ration of axial strain to hoop strain resulting from stress in the hoop direction.

<sup>(3)</sup>  $v_{ah}$  = The ration of hoop strain to axial strain resulting from stress in the axial direction.

## Typical Physical Properties

Pipe Property	Value	Value	Method
Thermal Conductivity Pipe Wall	0.19 BTU/hr·ft·°F	0.33 W/m·°C	NOV FGS
Thermal Expansion - Axial	12.0 x 10 <sup>-6</sup> in/in·°F	21.6 x 10 <sup>-6</sup> mm/mm·°C	ASTM D696
Flow Coefficient, Hazen Williams		150	-
Absolute Roughness	1.7 x 10 <sup>-5</sup> ft	5.3 x 10 <sup>-6</sup> m	-
Density	121 lbs/ft <sup>3</sup>	1940 kg/m <sup>3</sup>	ASTM D792
Specific Gravity		1.95	ASTM D792
Specific Heat	0.22 BTU/lb·°F	910 J/kg·°C	-

## Fiber Glass Systems

17115 San Pedro Avenue, Ste. 200, San Antonio, Texas 78232, USA

Phone: 210 477 7500 Fax: 210 477 7560

NOV Inc. has produced this brochure for general information only, and it is not intended for design purposes. Although every effort has been made to maintain the accuracy and reliability of its contents, NOV Inc. in no way assumes responsibility for liability for any loss, damage or injury resulting from the use of information and data herein nor is any warranty expressed or implied. Always cross-reference the bulletin date with the most current version listed at the web site noted in this literature.