



FRP Bridge Drain Pipe

Perfecting Bridge Drain Systems for More Than 30 Years

Features

Corrosion Resistant



Providing our clients with a no-rust, no-rot pipe is one of our most basic benefits. There is no corrosion with a fiberglass bridge drain system. Fiberglass is inert to oil, gas, salt, ice-melting solutions and many other corrosive compounds found on highway structures. Even cleanouts and roadway scuppers are nonmetallic, resulting in a system that will never require replacement due to a corrosion-related failure.

Lightweight



Fiberglass drain piping can be up to 10 times lighter than equivalent metallic systems. This allows the installer to reduce the crew sizes required on-site as just one laborer can handle full sticks of pipe and fittings. Even though the material is light, the mechanical properties of fiberglass still fall more closely in line with steel products rather than weaker thermoplastics like PVC.

Easy Installation



A major advantage of a fiberglass drain system lies in its prefabrication capabilities. On-site deliveries can easily include preassembled joints, collectors, cleanouts and even directional changes. This option saves a lot of time and energy for the contractor in the field, which will ultimately save money. The lightweight nature of fiberglass also limits the need for heavy machinery used to handle the materials, decreasing installation costs even further.

Custom Fabrication



If you can draw it, we can build it. Custom and specific fittings are easily fabricated by our American manufacturer – they have been doing so since 1984! This includes any specialty items such as catch basins or hoppers, odd degree elbows, oval fittings, square and even rectangular components. We can also make any combination of these items to ensure the drainage system we install is as unique as the bridge it serves.

Case Histories

Pulaski Skyway Rehab

Viaduct over the New Jersey Meadowlands

Grace Composites worked with the installing contractor to design and develop nearly 35,000 linear feet of prefabricated pipe spools. This partnership ensured the project was completed within budget and ahead of schedule.



Centennial Bridge

Crosses the Missouri River in Leavenworth, KS

While engineers planned the bridge deck drain replacements for this retrofit project, they searched for other bridge components that could benefit from an FRP alternative design. In all, 56 custom fiberglass girder inspection door hatch covers were installed.



Benjamin Franklin Bridge

Crosses the Delaware River in Philadelphia, PA

Our previous success with the Commodore Barry Bridge led to this project, our second opportunity to team up with the Delaware River Port Authority. All pipe and fittings supplied for the project were matched to Benjamin Franklin Blue per the contract requirements.



Fittings, Troughs & Accessories

Fiberglass bridge drain projects require fittings, scuppers, expansion joints and related accessories. Fittings are pigmented to match pipe and/or existing colors. Any color from the federal 595 color chart can be matched. Standard and custom fittings are available to fit most any bridge drain pipe configuration. Cleanouts can also be added to any fitting type to improve the long-term maintenance of the system. A white PVC removable plug is included at each cleanout location but other options are available if desired.

The FRP components we offer engineers only begin with the pipe and fittings. Girder inspection manhole covers, bearing catchments, rectangular pipe and even bird or other pest control items can be manufactured using fiberglass reinforced plastics.



Chicago Skyway

Crosses the Calumet River and Calumet Harbor in Chicago, IL

Despite being one of our first mega projects, the installation of the Chicago Skyway's drainage system was completed by two workers and a manlift. The overall system design consisted of nearly 15,000 linear feet of pipe and hundreds of custom fittings.



Joe Montana Skyway

Pennsylvania Turnpike 43 South of Pittsburgh, PA

The FRP bridge drain pipe system's range of custom colors allowed engineers to blend pipes with the bridge's color scheme. The bridge's extreme elevation reaches more than 200 feet in some places.



Chapel Lane Extension

Trough drains for I-459 structure in Hoover, AL

When extending Chapel Lane, the Alabama DOT needed to control the interaction between the new and existing roadways. Limited by the design of the I-459 drainage layout, 400 linear feet of fiberglass troughs were installed to help improve safety for new roadway users.



Peace Bridge

Crosses the Niagara River in Buffalo, NY

With operational responsibilities shared by the New York DOT and the Ontario MTO, the use of fiberglass drain products required joint approval. A series of roller hangers were used to help speed up installation times by allowing contractors to push and pull the pipe through the supports while maintaining a static location for pipe assembly.



Huey P. Long Bridge

Crosses the Mississippi River west of New Orleans, LA

The Huey P. Long Bridge opened in 1935 as New Orleans' first Mississippi River crossing. By 2012, wear and tear forced engineers to make heavy investments toward rehab for the structure, with the inclusion of a new fiberglass drainage system being a part of their overall scope. That same year, the structure was declared by the ASCE as a National Civil Engineering Monument.



New River Gorge Bridge

Crosses the New River in Fayette County West Virginia

As one of the tallest vehicular bridges in the world, this structure attracts nearly 100,000 guests for the Fayette County Bridge Days each year. When de-icing salts began to accelerate pack rusting at the deck joints, WVDOT engineers not only invested in the rehab of rusty components but also addressed the cause of the corrosion by installing a full capture FRP drain system.

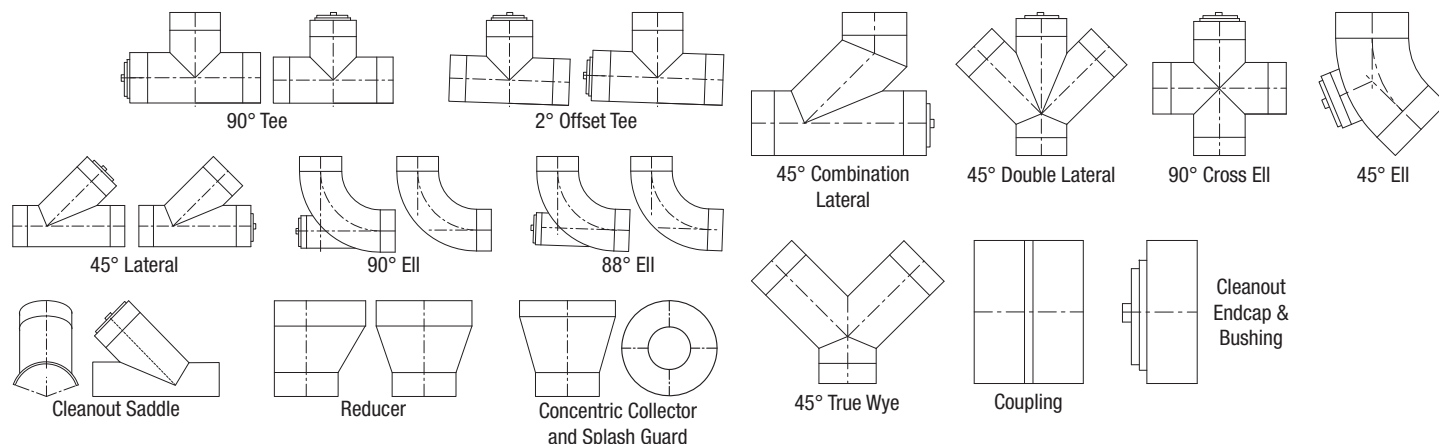

Technical Data

FRP Pipe

Bridge and highway piping is filament wound composite pipe consisting of a thermosetting resin and continuous glass filament structural reinforcement. It is available in standard sizes of 4-24 inches. Larger sizes are available upon request.

Joining Methods

An adhesive bonded socket joint is the primary joining method for FRP bridge drain pipe. All other typical joining methods are available.



View the installation video!

Dimensional Data

Nominal Size		Nominal I.D.		Nominal O.D.		Nominal Coupling O.D.		Average Wall Thickness		Support Spacing @0.5" Deflection		Nominal Weight	
(in.)	(mm)	(in.)	(mm)	(in.)	(mm)	(in.)	(mm)	(in.)	(mm)	(ft.)	(m)	(lbs./ft.)	(kg/m)
4	100	4.00	101	4.25	108	4.34	110	.125	3.2	16.5	5.0	1.3	1.9
6	120	6.35	160	6.60	168	6.94	176	.125	3.2	18.3	5.6	2.0	3.0
8	200	8.23	208	8.48	215	8.82	224	.125	3.2	20.2	6.2	2.6	3.9
10	250	10.23	259	10.48	266	10.82	275	.125	3.2	21.3	6.5	3.6	5.4
12	300	12.23	309	12.48	317	12.82	326	.125	3.2	22.4	6.8	4.4	6.6
14	350	14.23	360	14.48	368	14.82	376	.125	3.2	23.2	7.1	5.0	7.4
16	400	16.23	411	16.48	419	16.82	427	.125	3.2	24.0	7.3	5.7	8.5
18	450	18.23	462	18.48	469	18.82	478	.125	3.2	24.8	7.6	6.9	10.3
20	500	20.23	514	20.56	522	20.90	531	.165	4.2	25.7	7.8	8.3	12.3
24	600	24.23	615	24.56	624	24.90	632	.165	4.2	26.7	8.2	9.9	14.6

* All values are nominal, tolerances or maximum/minimum limits can be obtained from the manufacturer: Grace Composites, 351 Ruth Road, Lonoke, AR 72086, Phone: 501-676-9505, Fax: 501-676-9515, E-mail: jeff@gracecomposites.com. A copy of the standard specifications are available for download at www.frbbridgedrainpipe.com.

Pipe Material Comparisons

	Fiberglass	PVC	Steel
Weight/Foot	3.6#	11.7#	40.5#
Minimum Support Spacing	21.3'	7.0'	22.0'
Expansion/Contraction	1.18"	2.52"	.5"
Ultraviolet Degradation	UV inhibitors present in standard products	Very susceptible to UV degradation	Not susceptible to UV degradation
Resistance to Salt	Good	Good	Poor, unless stainless or galvanized steel
Resistance to Solvents	Good	Poor	Poor, unless stainless or galvanized steel
Resistance to Acids	Good	Good	Poor, unless stainless or galvanized steel
Resistance to Gasoline	Good	Poor	Poor, unless stainless or galvanized steel
Custom Colors	No paint required	Requires paint	Requires paint
Custom Bridge Drain Fittings	Available and easily fabricated	Not available	Not available

Note: Above conditions are based on using 10" diameter pipe. Expansion/contraction calculated using a 70 degree change in temperature per 100 foot of pipe.



Grace Composites
351 Ruth Road
Lonoke, AR 72086
Phone: (501) 676-9505
Fax: (501) 676-9515



frbbridgedrainpipe.com



Made in the USA