

SILVER STREAK® LD FITTINGS DIMENSIONS

Silver Streak LD piping and fittings are designed especially for abrasive and corrosive services such as limestone and gypsum slurries found in flue gas desulfurization (FGD) scrubber applications.

Silver Streak LD piping systems are designed to operate at temperatures up to 200°F and pressures up to 150 psig.

Sweep elbows are available in 30 ° diameters only.

Fittings are constructed with the same abrasion-resistant additives as the pipe.

All fittings have a nominal corrosion/abrasion barrier of 100 mils.

Stub Flange

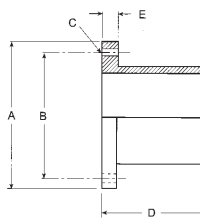

Nominal Pipe Size	A	B	C	D	Bolts	E (psi)		
						50	75	100
In	In	In	In	In	Size - No			
30	38 3/4	36	1 3/8	15	1 1/4 - 28	1 7/8	2 1/8	2 1/4*
36	46	42 3/4	1 5/8	15	1 1/2 - 32	2	2 3/8	2 1/2*
42	53	49 1/2	1 5/8	15	1 1/2 - 36	2 1/8	2 5/8*	2 7/8*
48	59 1/2	56	1 5/8	18	1 1/2 - 44	2 1/4	2 3/4*	3 1/8*

*Flange has special "O" ring type seal. Consult factory for design of each of these flange connections since only one flange face is grooved for placement of the seating "O" ring. Quotations or information on gasket requirements available on request. Flanges meet O.D., bolt circle diameter, number of holes and bolt hole diameter dimensions for ANSI B16.1 125 lb.

Weights Per Fitting

Nominal Pipe Size	Plain Ends			Flanged			Flange Stub End Drilled
	Elbow	Elbow	Tee	Elbow	Elbow	Tee	
In	90°	45°	BBB	90°	45°	FFF	
30	280	140	280	455	315	545	125
36	445	220	420	710	490	820	185
42	665	330	600	1050	730	1190	265
48	945	475	870	1460	985	1640	355

90° Elbow

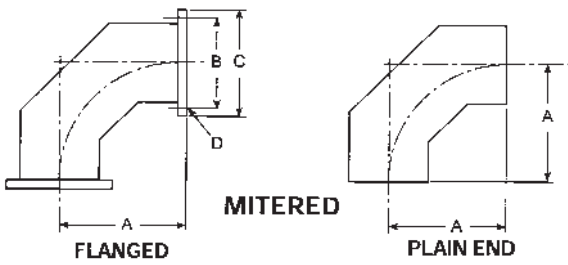

Nominal Pipe Size	A	B	C	Bolt Holes D	Bolts .
In	In	In	In	Diameter	Size/No.
30	45	36	38 ¾	1 ⅜	1 ¼ - 28
36	54	42 ¾	46	1 ⅝	1 ½ - 32
42	63	49 ½	53	1 ⅝	1 ½ - 36
48	72	56	59 ½	1 ⅝	1 ½ - 44

Elbows will be mitered construction using pipe for the mitered sections. Elbows shall have a minimum of 2 miters. Sweep elbows available in 30" only.

45° Elbow

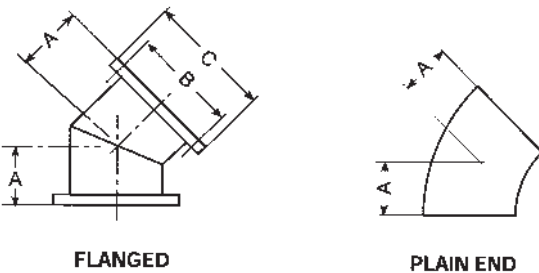

Nominal Pipe Size	A	B	C	Bolt Holes D	Bolts .
In	In	In	In	Diameter	Size/No.
30	18 ⅝	36	38 ¾	1 ⅜	1 ¼ - 28
36	22 ½	42 ¾	46	1 ⅝	1 ½ - 32
42	26	49 ½	53	1 ⅝	1 ½ - 36
48	29 ⅞	56	59 ½	1 ⅝	1 ½ - 44

Elbows will be mitered construction using pipe for the mitered sections. All mitered elbows shall have 1 miter, 2 sections. Sweep elbows available in 30" only.

Tee

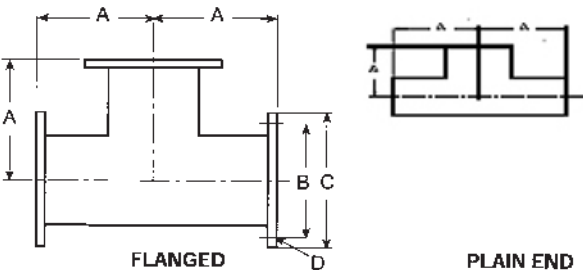

Nominal Pipe Size	A	B	C	Bolt Holes D	Bolts .
In	In	In	In	Diameter	Size/No.
30	30	36	38 ¾	1 ⅜	1 ¼ - 28
36	33	42 ¾	46	1 ⅝	1 ½ - 32
42	36	49 ½	53	1 ⅝	1 ½ - 36
48	42	56	59 ½	1 ⅝	1 ½ - 44

Cross

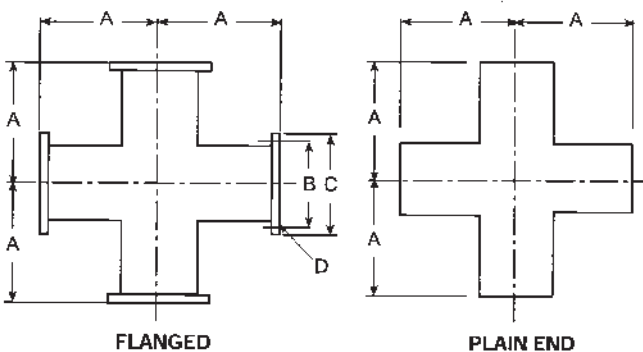

Nominal Pipe Size	A	B	C	Bolt Holes D	Bolts .
In	In	In	In	Diameter	Size/No.
30	30	36	38 ¾	1 ⅜	1 ¼ - 28
36	33	42 ¾	46	1 ⅝	1 ½ - 32
42	36	49 ½	53	1 ⅝	1 ½ - 36

Lateral

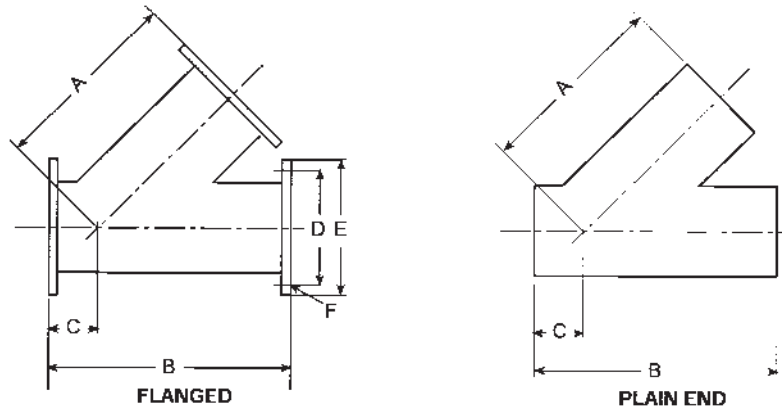

Nominal Pipe Size	A	B	C	D	E	F	Bolts .
In	In	In	In	In	In	In	Size/No.
30	52	72	20	36	38 ¾	1 ⅜	1 ¼ - 28
36	62	84	22	42 ¾	46	1 ⅝	1 ½ - 32
42	72	96	24	49 ½	53	1 ⅝	1 ½ - 36

Reducer

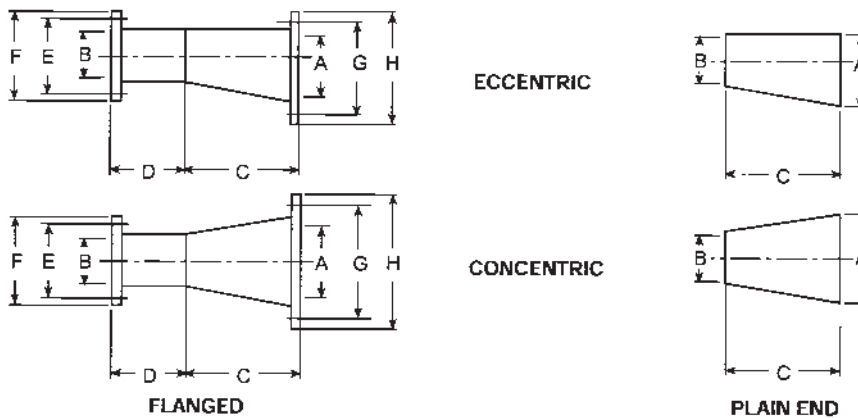

Nominal Pipe Size A/B	C	D	E	F	G	H
In	In	In	In	In	In	In
30 x 20	25	12	25	27 ½	36	38 ¾
30 x 24	15	12	29 ½	32	36	38 ¾
36 x 24	30	12	29 ½	32	42 ¾	46
36 x 30	15	15	38 ¾	36	42 ¾	46
42 x 30	30	15	38 ¾	36	49 ½	53
42 x 36	15	15	42 ¾	46	49 ½	53

National Oilwell Varco has produced this brochure for general information only, and it is not intended for design purposes. Although every effort has been made to maintain the accuracy and reliability of its contents, National Oilwell Varco in no way assumes responsibility for liability for any loss, damage or injury resulting from the use of information and data herein nor is any warranty expressed or implied. Always cross-reference the bulletin date with the most current version listed at the website noted in this literature.

North America

17115 San Pedro Ave. Suite 200
San Antonio, Texas 78232 USA
Phone: 210 477 7500

South America

Avenida Fernando Simoes
Recife, Brazil 51020-390
Phone: 55 31 3501 0023

Europe

P.O. Box 6, 4190 CA
Geldermalsen, The Netherlands
Phone: 31 345 587 587

Asia Pacific

No. 7A, Tuas Avenue 3
Jurong, Singapore 639407
Phone: 65 6861 6118

Middle East

P.O. Box 17324
Dubai, UAE
Phone: 971 4881 3566